



CONDAIR RM

Low capacity resistive steam humidifier
Compact and efficient performance



Compact resistive steam humidifier offering 2-8kg/h for in-duct humidification

Service-friendly design

The design of the Condair RM allows all maintenance work to be carried out at the front. This means that even in situations where there is limited space or only front access, the system can be serviced.

Cleanable boiling chamber

The boiling chamber is equipped with ergonomic clamps that allow it to be opened and cleaned in just a few easy steps.

Side connection and floor mounting

In the event that the unit cannot be wall-mounted, an optional floor stand is available with all services being delivered via the side rather than the bottom of the humidifier.



CONDAIR RM

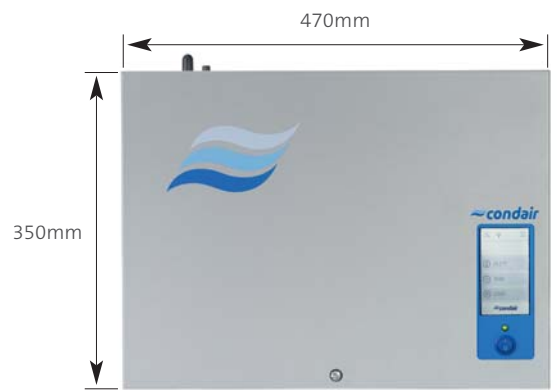

Compact dimensions

With a compact design, the Condair RM can be easily located in most plant rooms.

Touch-screen interface

A modern touch screen user interface makes control and programming straight forward.

Perfect integration into Building Management Systems

Modbus®

Water treatment (optional)

In order to reduce scale formation in the boiling chamber, water treatment systems and RO water filters can be used.



The Condair RM is ideal for applications like CRAC units in data centres, MRI suites and high-end residential applications.

It is also suited to offering zonal control on branch ducts, where a specific area of a building requires an independently managed humidity level.

The benefits of resistive technology include a cleanable rather than replaceable boiling chamber, the ability to operate on mains or RO water and more accurate humidity control than electrode boiler humidifiers.

Standard version

- Multilingual, user guided menu structure
Program, service and information level
- Real-time clock and timer programming
- Various control signals (0–10 V, etc.)
- RS485 interface with Modbus protocol
Terminal block
- Installation material (wall mounting)
- Fiber composite tank
- Blowdown pump

Accessories

- 1 Steam distributor
- 2 Steam distribution hose
- 3 Mesh filter valve
- 4 Filter cartridge
- 5 Drain hose
- 6 Open funnel with water separator

Options

- Remote touch display
- Floor mounting kit
- Filter cartridge
- Touch display

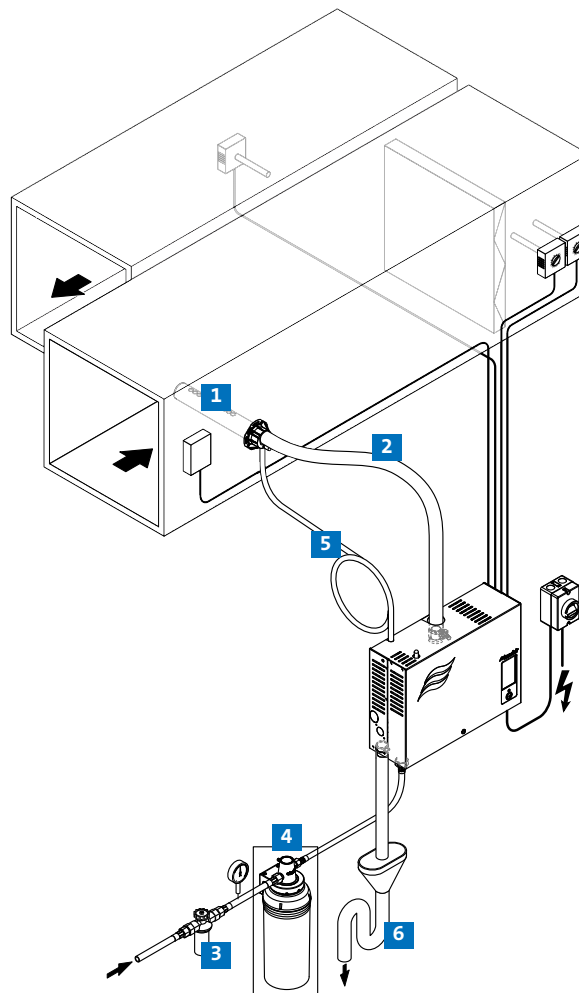

Technical data

		RM 2	RM 4	RM 6	RM 8
Steam output (nominal capacity)	kg/h	2.0	4.0	6.0	8.0
400 VAC / 3 Ph / 50–60 Hz	kW	-	-	5.0	6.5
230 VAC / 1 Ph / 50–60 Hz	kW	2.0	3.5	5.0	6.5
Control voltage	V/Ph/Hz	230 / 1 / 50–60			
Dimensions (W x H x D)	mm	470 x 350 x 150			
Operating weight	kg	12.9	12.9	12.9	12.9
Compliance		CE, VDE, DVGW			